

# **SNAP-LOC**<sup>TM</sup>

## Dust Seal System



**ARGONICS**

# SNAP-LOC™

## Dust Seal System

### ⚠ WARNING ⚠

Always obey all applicable safety rules.

Be sure all power to the conveyor has been disconnected and controls are locked out.

#### Installation tools required

- Tape measure
- Level
- Scribe and Chalk Line
- Welder
- Drill ( $\frac{1}{4}$ " and  $\frac{7}{16}$ " drill bits)

#### Parts required if bolt mounting

- Five  $\frac{1}{2}$ " x  $1\frac{1}{2}$ " grade 8 bolt, washer and nuts per 5' section (not supplied)
- $\frac{3}{16}$ " drill bit

#### Assembly Breakdown

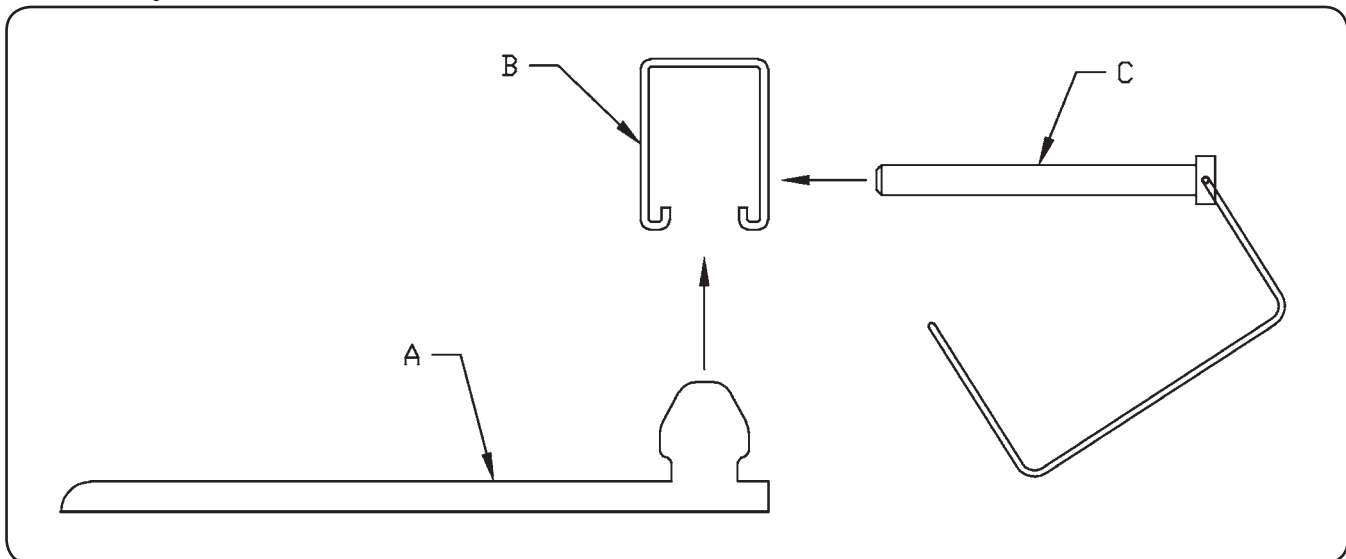

| Letter | Part Number    | Qty. | Description  |
|--------|----------------|------|--|
| A      | CP-SL“xxx”-G69 | 1    | Snap-Loc™ Belt Skirting $\frac{1}{2}$ " x 9" x “XXX” |
| B      | “x”d-60-i      | 1    | Snap-Loc™ Strut Channel 5'                           |
| C      | cp-esp-3835    | 1    | Safety Snap Pin $\frac{3}{8}$ " x $3\frac{1}{2}$ "   |

# INSTALLATION

The Snap-Loc™ Dust Seal system is an effective dust containment solution that is designed to fit most conveyor systems on the market today. Snap-Loc can be installed on conveyor belts with troughing angles of 20° to 45°. For the most effective sealing, the chute wall should be no more than ½" from the conveyor belt. Snap-Loc Dust Seal was not designed to contain the load on your belt.

## Step One: Layout

**Note: Argonics recommends that you have approximately 1/8 of the belt width extending beyond the outside of the chute wall. At the very minimum, Argonics recommends 4" to 5" on either side.**

Begin by making certain that the power to your conveyor system is shut down and that you follow your plant's "lock out" procedure. Next, clean and remove all obstructions from the belt, especially around the outside of the chute wall where you will be mounting the Snap-Loc Dust Seal system. If obstructions are non-removable, it may be necessary to cut, notch or omit the Snap-Loc strut channel at specific points along the conveyor. However, keep in mind that by omitting sections of the strut channel, the full containment seal will be compromised. Argonics recommends preserving the continuity of the strut channel and Dust Seal whenever possible to achieve the best results.

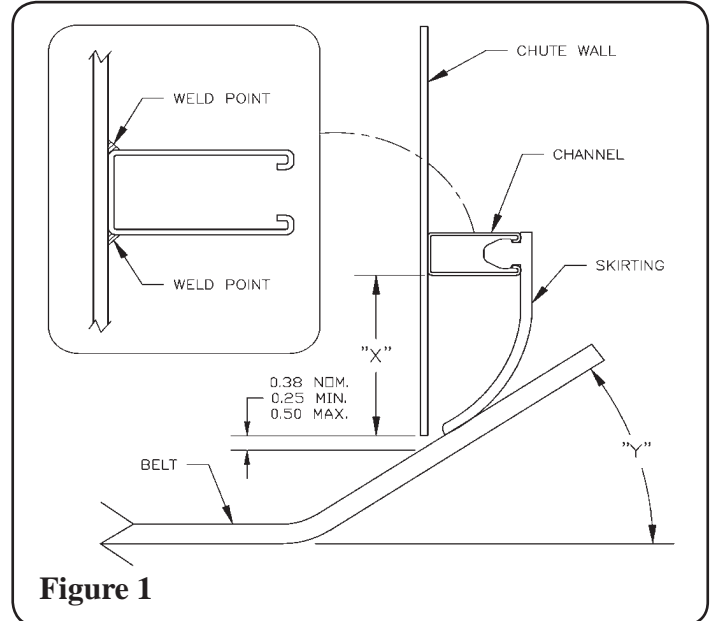

**Figure 1**

At one end of the chute wall measure up "X" (see Table 1) from the belt and mark the chute wall with a scribe. Repeat this step at the other end of the chute wall and then using a chalk line, snap a chalk line parallel to the belt line between the marked points on the chute wall. This line marks where the bottom of the Snap-Loc strut channel will be placed for mounting.

| Strut Channel Type | "X" Dimension   |                 |                |
|--------------------|-----------------|-----------------|----------------|
|                    | 20° Belt Angle  | 35° Belt Angle  | 45° Belt Angle |
| Single Wide        | 6.25"           | 6.14"           | 6.53"          |
| Double Wide        | 4.63"           | 4.51"           | 4.91"          |
| Single Narrow      | Not recommended | Not recommended | 7.54" *        |
| Double Narrow      | Not recommended | Not recommended | 5.92" *        |

\* *Narrow Rail should only be used on troughing angles of 45 degrees where possible*

**Table 1**

## Step Two: Mounting Snap-Loc strut channel

Place one 5' section of the Snap-Loc strut channel on the chute wall, making sure that you line up the base of the strut channel with the chalk line that you snapped in Step One and clamp the strut channel into place. **If bolt mounting:** Use a scribe to trace the inside diameter of the first and last holes in the strut channel. Then continue to trace the inside diameter of each hole 12-15" on center (see figure 2) over the length of the strut channel.

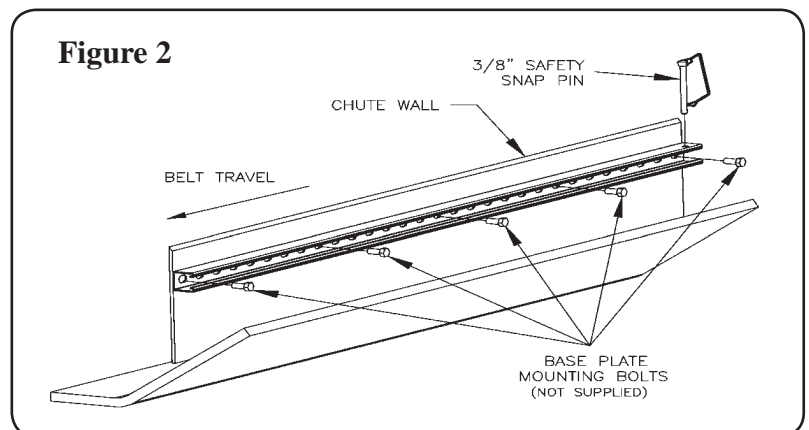

**Figure 2**

# SNAP-LOC™

## Dust Seal System

### Step Two - continued

Using a  $\frac{1}{16}$ " bit, drill holes in the center of the scribed outlines. Mount the strut channel to the chute wall using  $\frac{1}{2}$ " x  $1\frac{1}{2}$ " grade 8 bolts, washers and nuts (not supplied). Be careful not to overtighten the bolts or warping of the uni-strut may occur.

**If weld mounting:** Place 2" stitch welds every 15" along the top and bottom of the Snap-Loc strut channel (see Figure 1). Continue repeating this process with the rest of your 5' sections until your desired length is reached.

### Step Three: Installing Snap-Loc dust seal

Lay the Snap-Loc Dust Seal on the belt so the bulb is facing up and out, then starting on the tail section of the conveyor. Snap the bulb into the Snap-Loc strut channel using a rubber mallet if necessary, working your way toward the head pulley until you reach the end of your run. If you are encountering a snug fit between the strut channel and the Snap-Loc bulb, spray some soapy water on the urethane bulb before inserting it into the strut channel. Argonics recommends there be  $1\frac{1}{2}$ " to 3" of Snap-Loc in contact with the belt when properly installed.

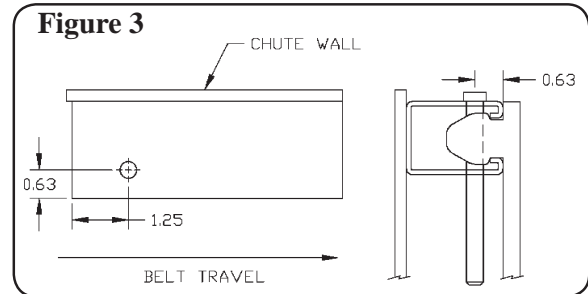

Mark the Snap-Loc strut channel  $1\frac{1}{4}$ " from the tail end of the channel and  $\frac{3}{8}$ " from the front (see Figure 3).

Drill a  $\frac{1}{4}$ " pilot hole completely through the end of the Snap-Loc strut channel and Snap-Loc bulb. Next bore the hole out with a  $\frac{7}{16}$ " drill bit. Insert the  $\frac{3}{8}$ " safety snap pin through the hole and fasten the spring catch to the pin. Let the Snap-Loc Dust Seal flow freely over the length of the conveyor.

## FOR CONTINUOUS RUNS OVER 60 FEET, CONSULT THE FACTORY

### Step Four: Adjustment

On Snap-Loc Dust Seal systems mounted using the single wide or single narrow uni-strut no adjustment is necessary.

On Snap-Loc Dust Seal systems mounted using the double wide or double narrow uni-strut on installation, use the upper channel for the uni-strut. When the Snap-Loc Dust Seal wears so the seal is straight down, then move the Dust Seal to the lower channel.

It is common for the Snap-Loc Dust Seal to stretch over time. If this occurs, simply cut the excess Dust Seal that is hanging past the head end of the strut channel.

**Your Snap-Loc Dust Seal system is now installed.**